

# MS-890



## Industrial Automation Scanner

The MS-890 is a heavy duty scanner with the flexibility to solve a multitude of applications under a variety of factory conditions. The extended read range and intelligent sweeping raster provide robust reading of both linear bar codes and stacked symbologies.

Versatility and rugged design make the MS-890 an ideal scanner for industrial applications.

### MS-890: At a Glance

- Decodes/second: 400 to 1000
- Read Range: 10 to 120" (254 to 3048 mm)
- IP65 Enclosure
- Optional IB-890 Wiring Box



ESP®: Easy Setup Program software provides quick and easy setup and configuration of all Microscan readers.



EZ Button: This performs reader setup and configuration with no computer required.



Visible Indicators: Performance indicators include "good read" green flash and LEDs, as well as the label positioning tool.



Sweeping Raster: This programmable feature enables the reader for multiple symbols at varying distances and locations.

For more information on this product, visit [www.microscan.com](http://www.microscan.com).

### MS-890: Available Codes



#### Long Read Range

The MS-890 optics were engineered for successful reading at extended or varying distances, such as a safety or clearance zone required around conveyor or assembly areas.

#### Visible Indicators

Illuminated LEDs on the MS-890 provide instant visual confirmation of successful reads. A "good read green flash" is projected from the front window and is visible within a 360 degree radius from the scanner.

#### Optional Wiring Box

The IB-890 wiring box provides easy and flexible integration, without any special cables or connectors. Features include:

- Ethernet
- Pluggable relay modules
- Terminal strip connectivity
- Connectivity with handheld scanners

#### Intelligent Raster

The MS-890 features an intelligent raster which can be optimized for scan angle and speed to read multiple symbols or inconsistently placed labels.

#### Autocalibration

The autocalibration feature automatically determines and selects optimal read settings for focus, gain and tracking.

#### Bar Code Programming

Changing scanner configuration on the factory floor is as simple as presenting a bar code and pushing the EZ button. This feature makes it simple to replicate settings on multiple MS-890 scanners.

#### Application Examples

- Light to heavy industry
- Forklifts or conveyor lines



# MS-890 INDUSTRIAL AUTOMATION SCANNER

## SPECIFICATIONS AND OPTIONS

### MECHANICAL

**Length:** 3.5" (88 mm)  
**Width:** 5" (127 mm)  
**Height:** 6" (152 mm)  
**Weight:** 5 lbs. (227 g)

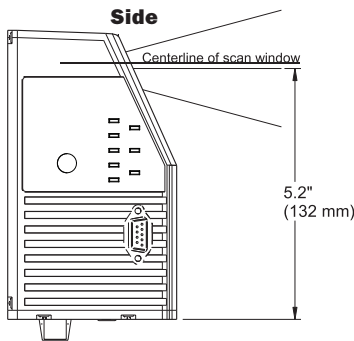

### Front

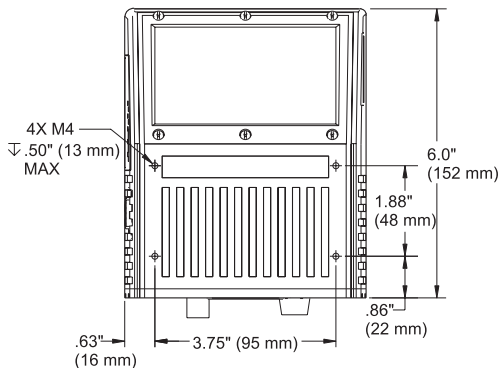

### Bottom

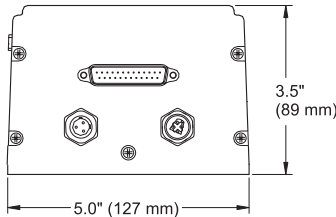

### ENVIRONMENTAL

**Enclosure:** IP65  
**Operating temperature:** 0° to 50°C (32° to 122°F)  
**Storage temperature:** -50° to 75°C (-63° to 167°F)  
**Humidity:** Up to 90% (non-condensing)

### LASER LIGHT

**Type:** Semiconductor visible laser diode (650 nm nominal)  
**Operating life:** 50,000 hours @ 25°C (77° F)  
**Safety class:** CDRH Class II

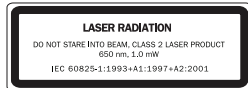

### SCANNING PARAMETERS

**Scanner mirror type:** Rotating, single line, 14-faceted mirror  
**Scan rate:** Adjustable from 400 to 1000 scans/second (default = 500 sps)  
**Raster Sweep Speed:** 1 to 30 sweeps per second  
**Raster Sweep Angle:** 30° maximum  
**Scan Width Angle:** Typically 60°  
**Pitch Angle:** ±50° maximum  
**Skew Angle:** ±40° maximum  
**Label contrast:** 25% min. absolute dark to light differential at 650 nm wavelength

### Read Ranges<sub>1</sub>

Symbol/Narrow Bar Width	Read Range
7.5 mil (.190 mm)	10" to 35" (254 to 889 mm)
10 mil (.254 mm)	10" to 44" (254 to 1118 mm)
15 mil (.381 mm)	10" to 74" (254 to 1880 mm)
20 mil (.508 mm)	10" to 90" (254 to 2286 mm)
30 mil (.762 mm)	10" to 100" (254 to 2540 mm)
40 mil (1.020 mm)	10" to 110" (254 to 2794 mm)
50 mil (1.27 mm)	10" to 120" (254 to 3048 mm)

<sup>1</sup> Readings are using a Code 39 grade A label

### CONNECTORS/PIN ASSIGNMENTS

**Program Connector:** 9-pin D-subminiature plug

Pin No.	Function
2	RX232
3	TX232
5	Signal ground
9	Boot mode

**Power Connector:** 3-pin microchange plug

Pin No.	Function
1	Power ground
2	NC
3	Power 10 to 28 VDC (in)

**Trigger Connector:** 4-pin microchange socket

Pin No.	Function
1	Power 10 to 28 VDC (out)
2	NPN
3	Ground
4	N/C

**Host Connector:** 25-pin D-subminiature plug

Pin No.	Host RS232	Host & Aux RS232	Host RS422/485	In/Out
1	Chassis ground			
2	Host TxD			Out
3	Host RxD			In
4	RTS	Aux TxD		Out
5	CTS	Aux RxD		In
6	Output 1 (+)			Out
7	Signal Ground			
8	Output 2 (+)			Out
9	Trigger (-)			In
10	Trigger (+)			In
11	N/C			
12	Input 1 (+)			In
13		RxD (+)		In
14		TxD (-)		Out
15	Noread/Output 3 (+)			Out
16		RxD (-)		In
17	Power Ground			
18	Power +10 to 28 VDC			In
19		TXD +		Out
20	Output 1 (-)			Out
21	Output 2 (-)			Out
22	Noread/Output 3 (-)			Out
23	Input 1 (-)			In
24	New master (-)			In
25	New master (+)			In

### COMMUNICATION

**Interface:** RS-232, RS-422/485, Daisychain/auxiliary port capable, Dedicated configuration port  
**Interface with IB-890 Wiring Box (optional):** Ethernet

### CODE TYPES

**Standard codes:** Code 39, Code 128, UPC/EAN, Interleaved 2 of 5, Codabar, Code 93, PDF417,  
**Applications Standard:** AIAG, UCC/EAN-128

### ELECTRICAL

**Power Requirement:** Input, 10-28 VDC, 200 mV p-p max. ripple, 230mA at 24 VDC (typ.)

### EMISSIONS AND IMMUNITY

**EN61000-6-3:2001:** for Class A products  
**EN61000-3-2:2000+A2:2005**  
**EN61000-3-3:1995+A1:2001**  
**EN61000-6-2:** Immunity

### INDICATORS

**Beeper:** Good read, match/mismatch, no read, serial command confirmation  
**LEDs:** 1 status, 1 power, 1 good read, and 5 read performance (representing percentage of good decodes), network/include status, green flash

### DISCRETE I/O

**Trigger, New Master, Input 1:** Optoisolated, 5-28V rated, (12mA at 24 VDC)  
**Outputs (1, 2, 3):** Opto-isolated, 1-28 VDC rated, (I<sub>CE</sub> < 100 mA @ 24 VDC, current limited by user)

### SAFETY CERTIFICATIONS DESIGNED FOR

FCC, CDRH, CE, UL/cUL, BSMI



ISO 9001:2000  
**Certified QMS**

### ROHS/WEEE COMPLIANT

### ISO CERTIFICATION

Issued by TÜV USA Inc, Member of TÜV NORD Group, Cert No. 06-1080

©2008 Microscan Systems, Inc. SP002B 09/08

Read Range and other performance data is determined using high quality Grade A symbols per ISO/IEC 15415 and ISO/IEC 15416 in a 25°C environment. For application-specific Read Range results, testing should be performed with symbols used in the actual application. Microscan Applications Engineering is available to assist with evaluations. Results may vary depending on symbol quality. **Warranty**—One year limited warranty on parts and labor. Extended warranty available.

## MICROSCAN®

**Microscan Systems, Inc.**

Tel 425 226 5700 / 800 251 7711  
 Fax 425 226 8250

### Microscan Europe

Tel 31 172 423360 / Fax 31 172 423366

### Microscan Asia Pacific R.O.

Tel 65 6846 1214 / Fax 65 6846 464

Part of a full range of sales tools available from our web site:

[www.microscan.com](http://www.microscan.com)

**Product Information:** [info@microscan.com](mailto:info@microscan.com)

**Tech Support:** [helpdesk@microscan.com](mailto:helpdesk@microscan.com)